

All Templates:

Every template has scribe lines for the guitar centerline and the scale length.

Every template should be positioned so that the text can be read right side up with the neck to your left.

Every template is labeled as a TOP or BOT template.

All depths are measured from the *top* of the guitar, even for bottom routes.

All routes can be accomplished with a 1/2" bearing-guided bit.

Installation videos are available on our web site at <http://evertune.com>

F&T TOP 1 and F&T TOP 1X:

Securely mount the template F&T TOP 1X to top of body in the proper location. Then mount F&T TOP 1 right on top of it. Drill four holes all the way through the body of the guitar using a #7 drill bit (diameter .201"). Then chamfer the holes to remove the guitar finish from the hole edge and prevent chipping.

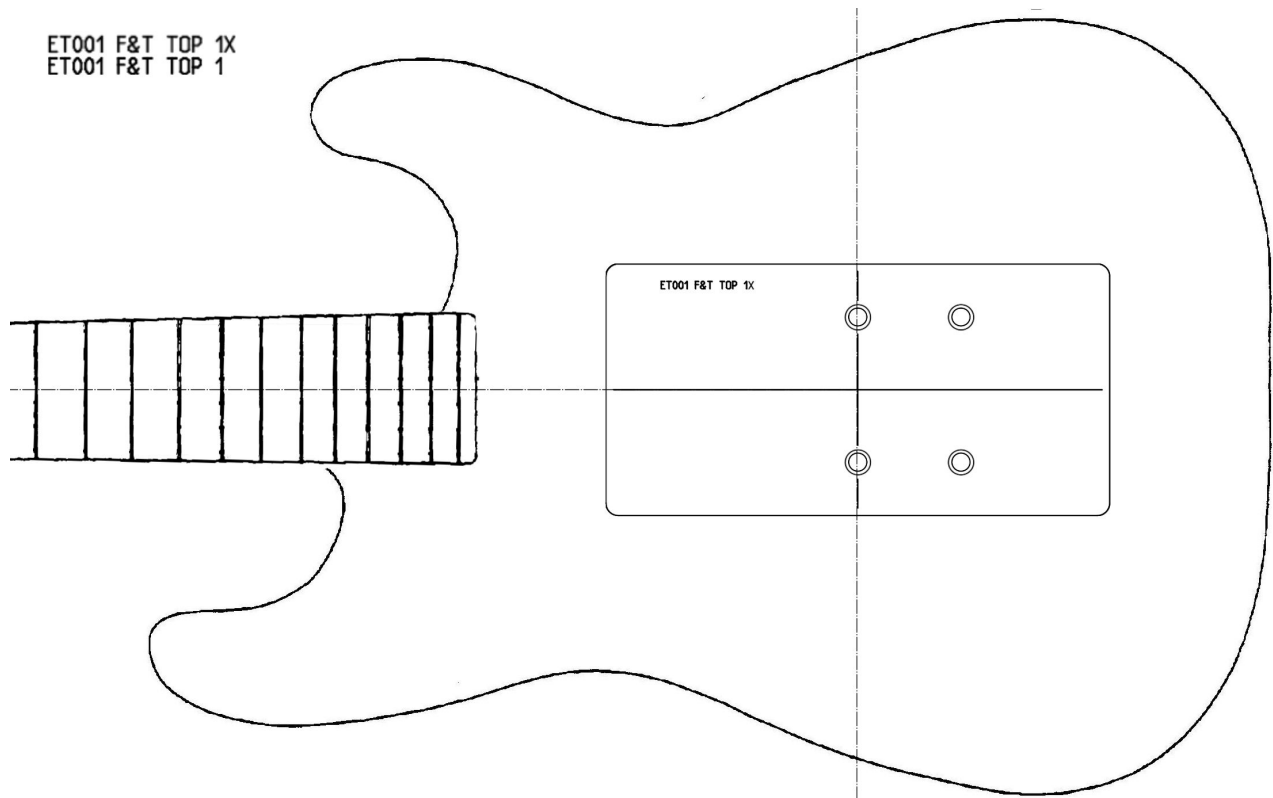

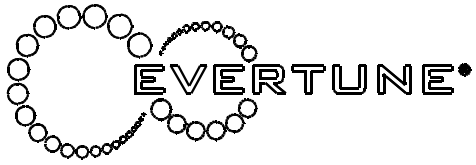

T TOP 2 or F TOP 2:

Apply double-sided tape to the top of the guitar and put the two #7 drill bits in the rear two holes. Slide the template down over the drill bits and onto the tape. Remove the drill bits and route at least one inch deep into the body. There is a small notch in one side of the template- don't worry, you didn't nick it with the router! If this is an F bridge on a guitar with no pick guard, now is a good time to use a Dremel tool to create the required chamfer at the front edge of the pocket. See drawing below for an idea of what this chamfer has to look like.

ET001 T TOP 2

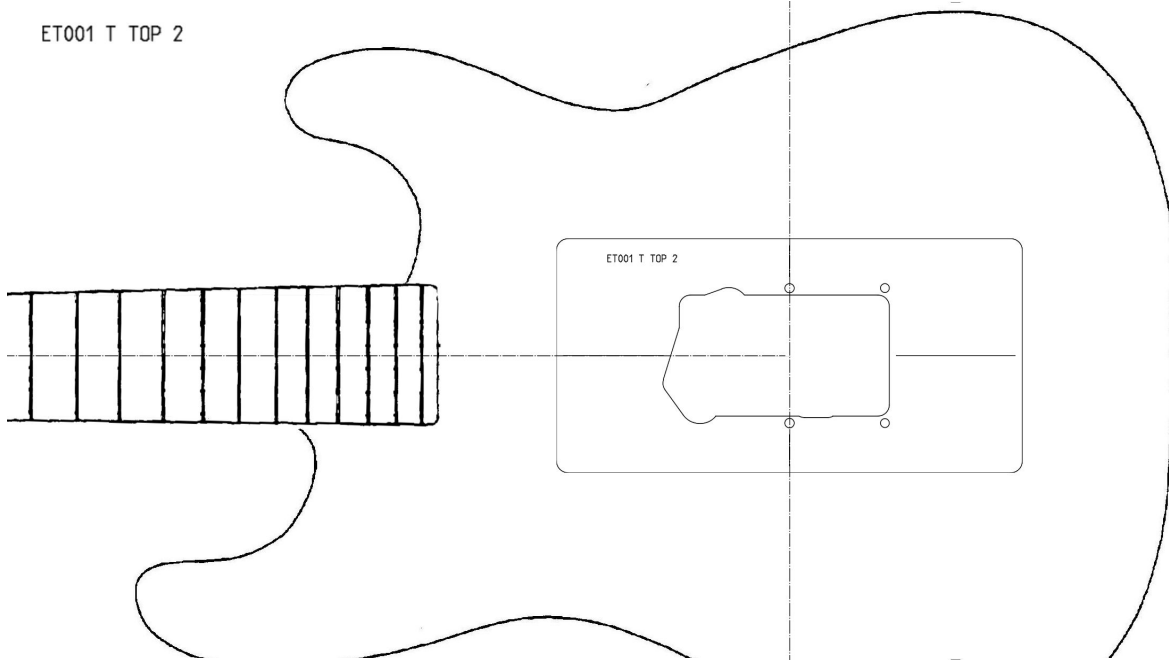

ET001 F TOP 2

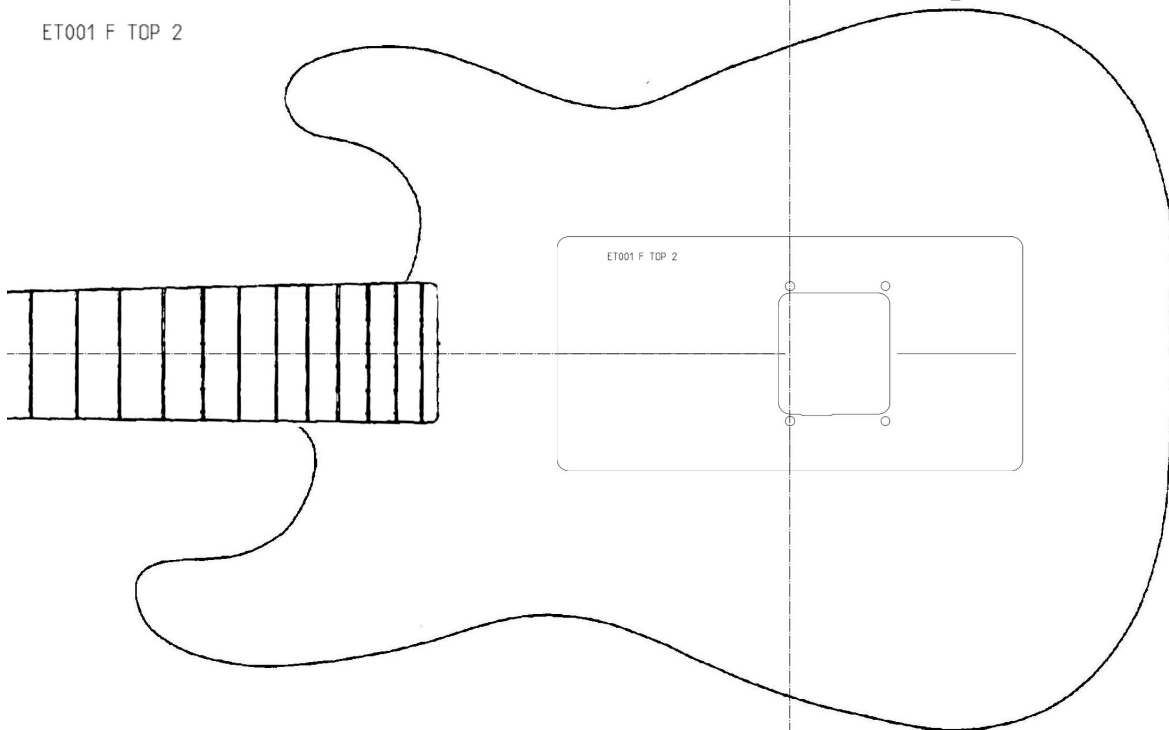

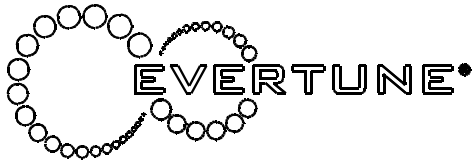

F&T BOT 1:

Mount the template to bottom of the guitar, using the two #7 drill bits to align it. Using a 1/16" drill bit, drill pilot holes for the back plate using the holes in the template as a guide. If you have a symmetrical back plate, use the three "T" holes as guides. For asymmetrical back plates, use the three "F" holes instead. Chamfer the pilot holes to remove the guitar finish to a diameter of 1/8" or more to protect the finish from cracking.

ET001 F&T BOT 1

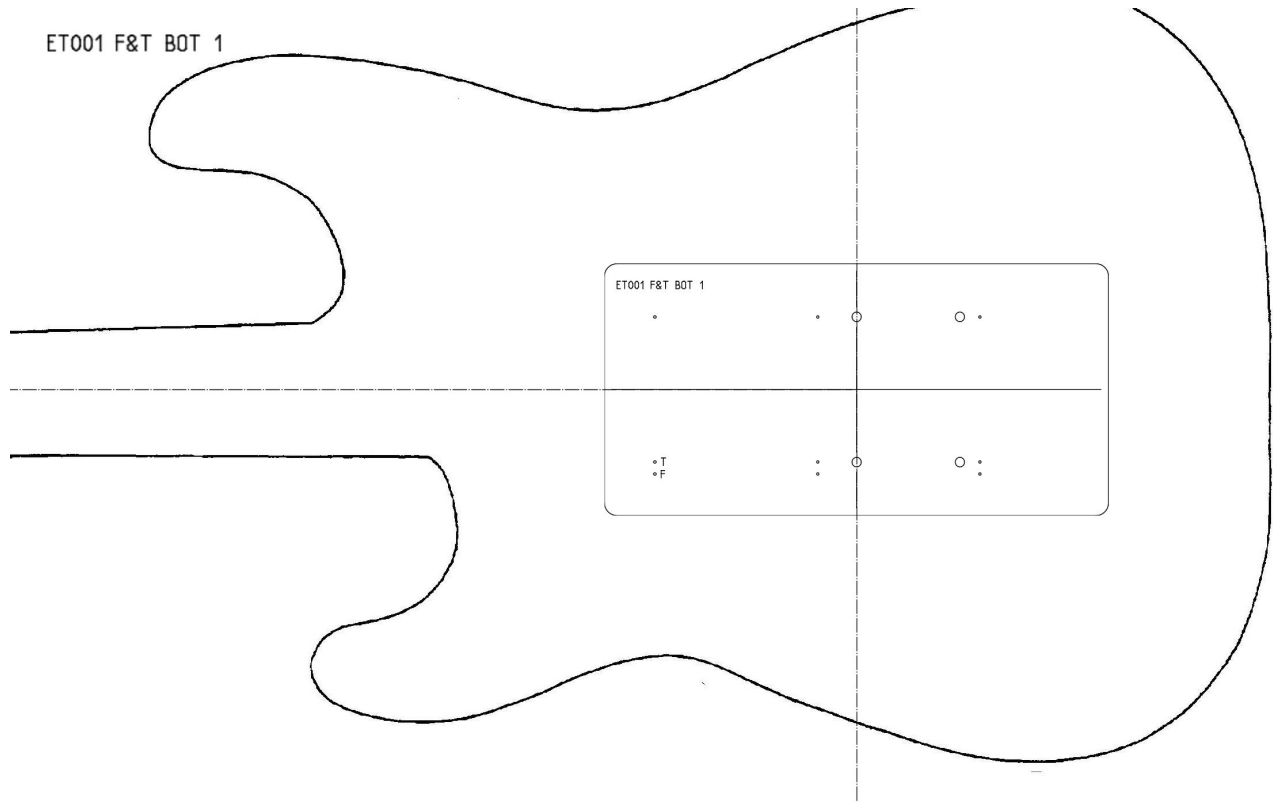

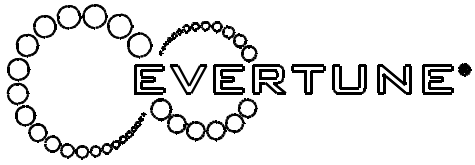

F&T BOT 2:

Mount the template to bottom of the guitar, using the four 1/16" drill bits to align it. You will need to space this template away from the back of the guitar using two thinner templates on each end. Route the smaller pocket to a depth that is 1.700" from the top of the guitar. Remember that since these depths are measured from the *top* of the guitar you have to subtract this number from the body thickness to get the router depth setting. If the guitar body is 1.750 inches thick, then the actual router cut depth would be 0.050 inches.

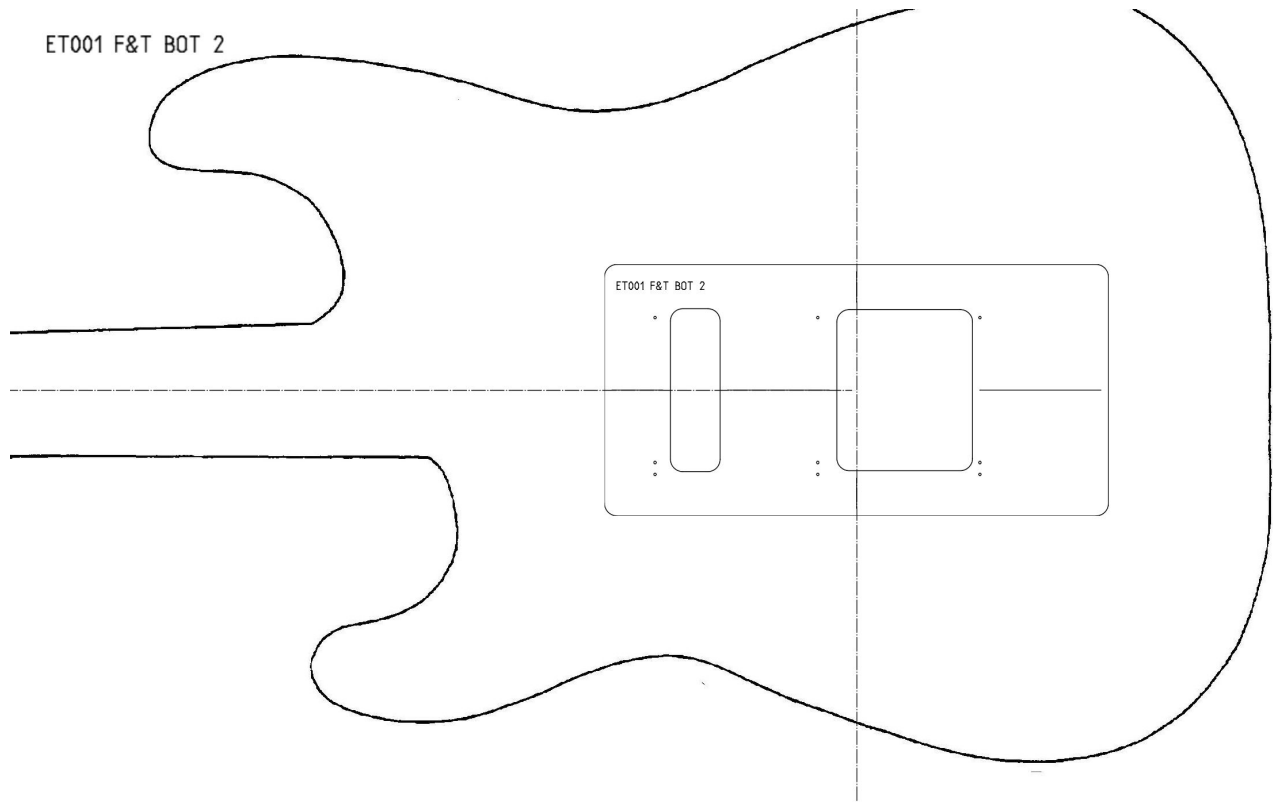

F&T BOT 2:

Use the same template again to route the larger pocket to a depth that is one inch from the top of the guitar. Remember that since these depths are measured from the *top* of the guitar you have to subtract this number from the body thickness to get the router depth setting. If the guitar body is 1.750 inches thick, then the actual router cut depth would be 0.750 inches.

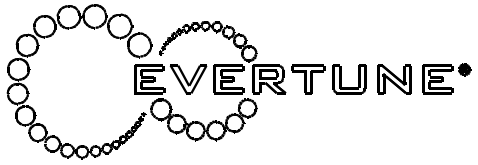

F&T BOT 3:

Align and mount the template to the bottom of the guitar. Route the pocket to a depth that is .850 inches from the *top* of the guitar. If the guitar body is 1.750 inches thick, then the router cut depth would be .900 inches.

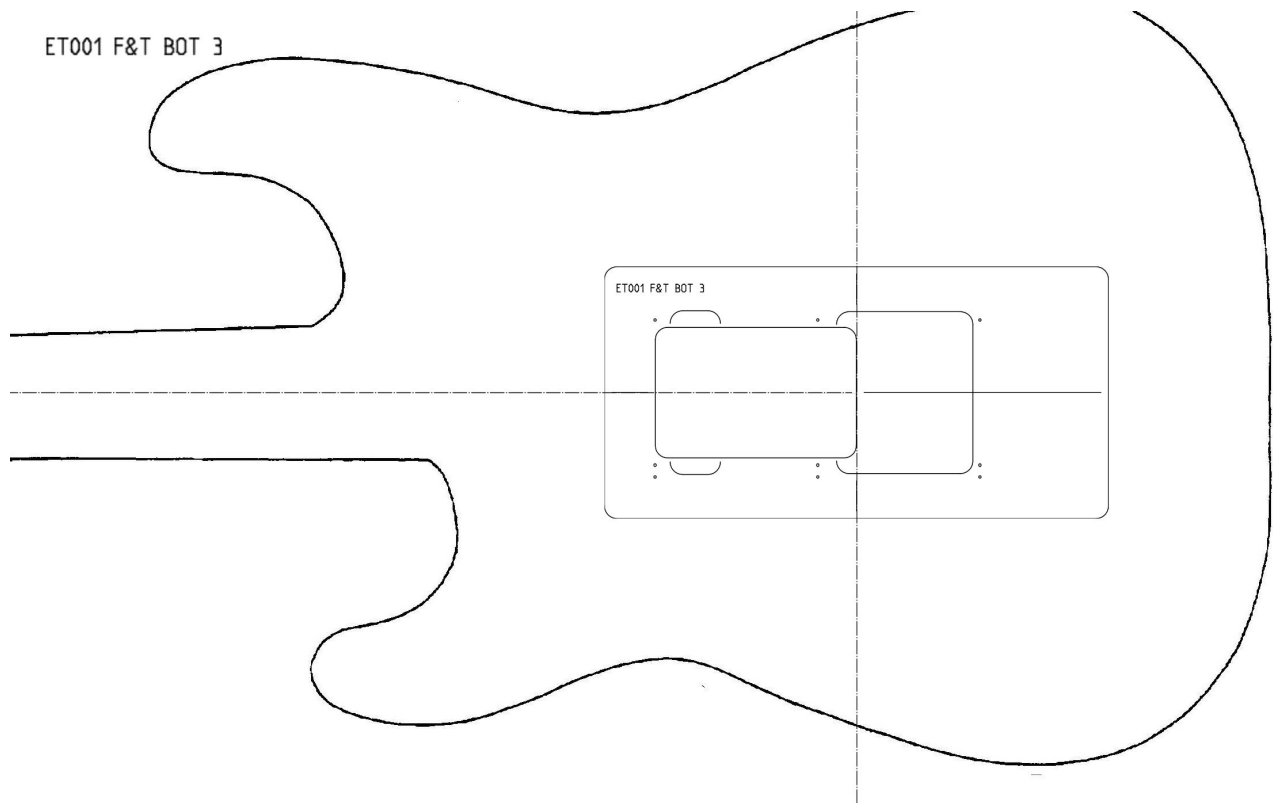

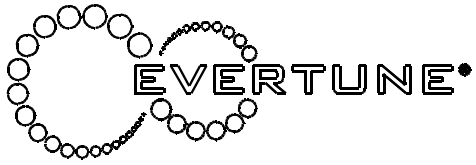

F BOT 4:

For "F" routes, this additional template is required. Align and mount the template to the bottom of the guitar and route to a depth that is 0.250 inches from the *top* of the guitar. If the guitar body is 1.750 inches thick, then the router cut depth would be 1.500 inches.

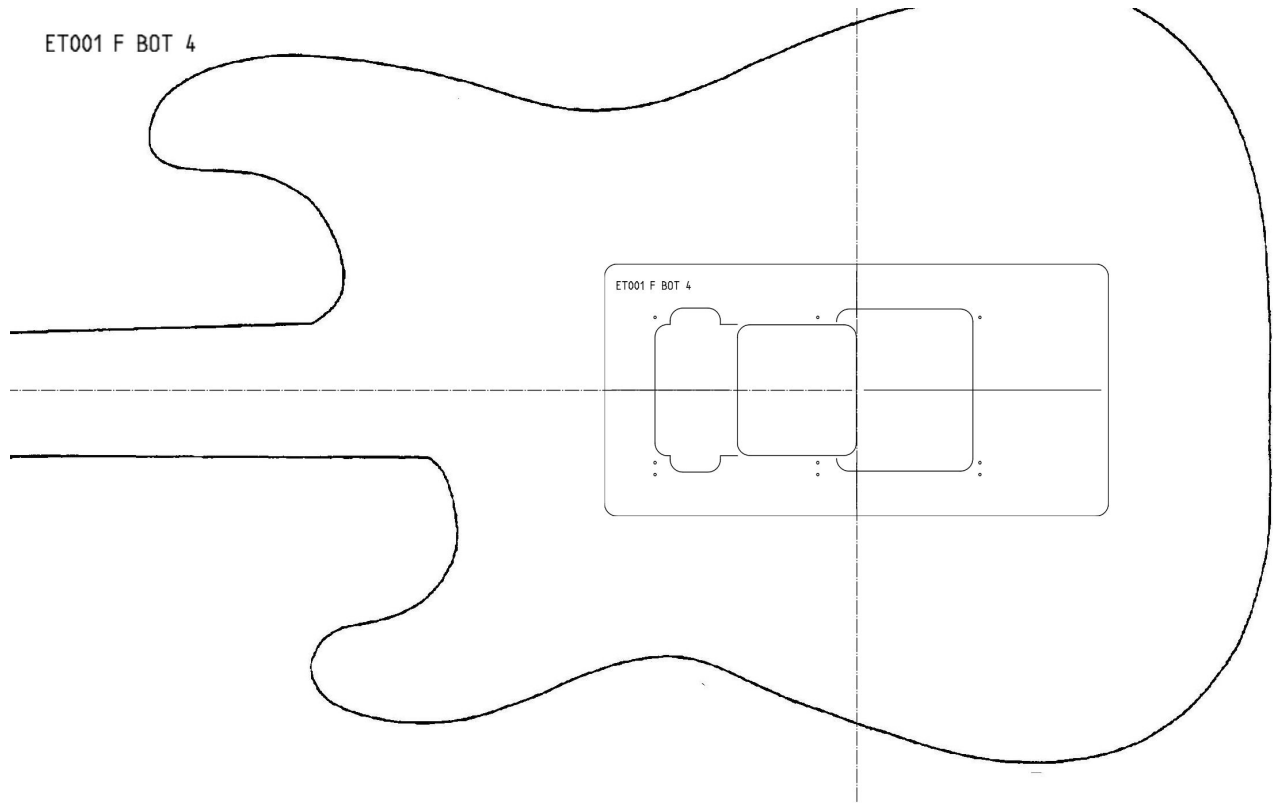

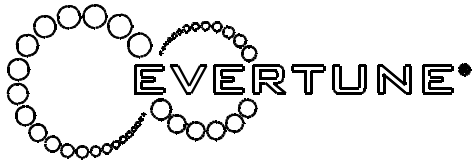

SPECIAL NOTES ON ROUTING FOR AN "F" STYLE BRIDGE

- o If the guitar is **already routed for a traditional tremolo**, you must use an F-style backplate which is asymmetrical and will cover the old route.
- o If the guitar **has not been routed for a tremolo** previously, then you have the option of using a symmetrical T-style backplate.
- o If the guitar **has a standard pick guard**: The routing template leaves behind a 1/4" thick piece of wood between the pickup pocket and the bridge pocket that can be removed.
- o If the guitar does **not have a pick guard**, then the 1/4" thick piece of wood between the bridge pocket and pickup pocket needs to be chamfered 1/2" on the bottom to clear the bridge modules. It is a good idea to do that before routing the bottom of the guitar. See Note 1 in drawing below:

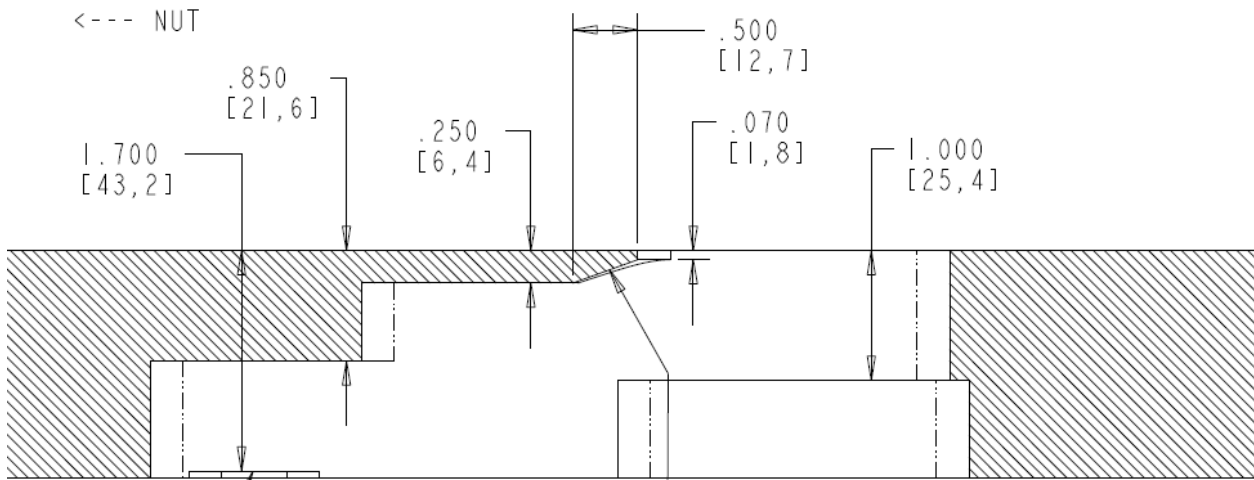

RECESS FOR FOOTPLATE

1). .250" THICK CHAMFERED WOOD SECTION BETWEEN BRIDGE ROUTE AND BRIDGE PICKUP CAN BE REMOVED FOR APPLICATIONS WITH PICKGUARDS

2010-11-30 ET001F BODY ROUTE SECTION VIEW SHEET 4 OF 5

EVERTUNE
 FULL SCALE
 DUAL DIMENSIONS: INCH [MM]



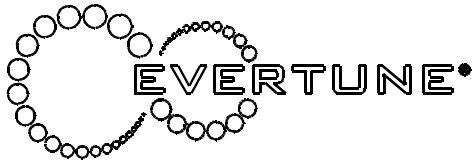

INSTALLING THE BRIDGE

1). INSERT THE BRIDGE

Slip the pre-assembled bridge in from the top and insert the four mounting lugs of the faceplate into the four corresponding holes in the body. It is recommended to slightly chamfer the holes first to avoid chipping the paint. If your guitar has a pick guard you may have to trim it.

2). SECURE THE BRIDGE

Using the two Mounting Plates (10017) and four Mounting Screws (10031), screw the bridge in place from below. The Evertune Tool can be used to tighten the screws.

3). SCREW IN THE FOOT PLATE

Locate a ground wire, and trap the bare end under the Foot Plate (10015) as you screw it in place with the provided screws (10033). You could also ground to a bridge Mounting Screw. There are lots of other places to ground the bridge as well, just keep in mind that the modules have to be free to move in the cavity, so the wire should not be in the way.

4). ATTACH THE BACK PLATE

The back plate mounts with six screws (10038).