

**All Templates:**

Every template has scribe lines for the guitar centerline and the scale length.  
Every template should be positioned so that the text can be read right side up with the neck to your left.  
All routes can be accomplished with a 1/2" bearing-guided bit.  
Installation videos are available on our YouTube channel at [http:// youtube.com/evertune8](http://youtube.com/evertune8)

**Find the True Scale Length**

Before you start, remove the old bridge, pickups, and anything else that is in the way. Also, accurately find and mark the true scale position (1) on the top of the guitar body. An easy way to do this by taking a legal sized sheet of paper, folding it lengthwise, and using the folded edge as a measuring tool. Lay the paper on the frets with the folded edge aligned to the center of the neck and with one end of the folded edge touching the nut. Mark the center of the 12th fret on the folded edge. Next spin the paper 180 and align that same mark with the 12th fret. Now the end of the paper that was at the nut is down at the bridge end. Mark the guitar at this end of the paper. This mark (1) is the true scale length.

**Find the Centerline of the Guitar**

Put a straightedge against one side of the neck and make a mark (2) on this line near the scale length mark (1). It is helpful to use a square block to help accurately transfer the mark location on arch top guitars. Do the same on the other side (3), and find the center point between the two marks.

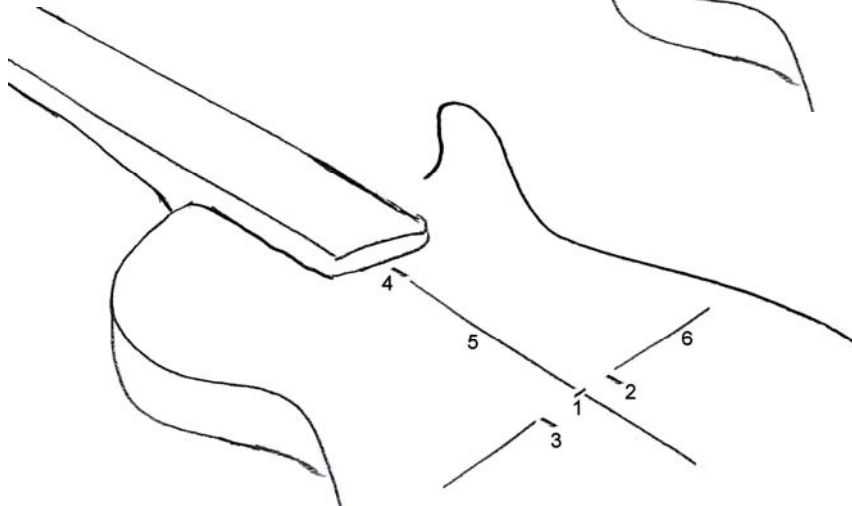
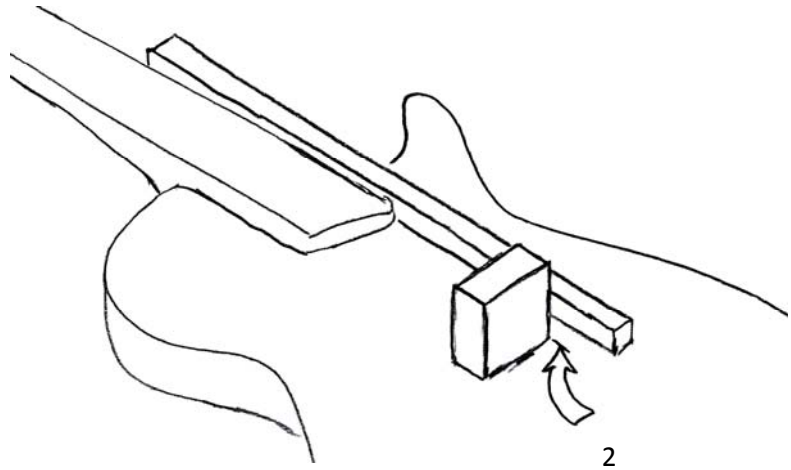

Mark the center of the neck (4), and connect the two center marks to form a long centerline mark (5). Draw a line (6) perpendicular to the center line of the guitar at the scale length, extending to both sides of the route area. The centerline (5) and scale line (6) are used to align the templates.

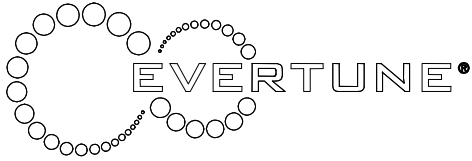

### **Obtain Donor Plugs For Matching the Finish**

Using the G2 template as a guide, mark the rectangular routing area on the top of the guitar. Then using the plug cutters, cut as many 1/2" and 1/4" donor plugs as you think you will need. If you can use the 1/4" donor plugs to fill the bridge mounting holes, you won't need color matched 1/2" plugs and you can glue the 1/4" plugs in directly. If you elect to use the 1/2" plugs, use a 1/2" router bit in your drill press to make clean 1/2" diameter pockets for the 1/2" donor plugs. You can cheat this pocket towards the center to minimize the visual impact.

### **Install Threaded Inserts**

- o Remove the tailpiece inserts if you haven't already.
- o Cut some 1/2" plugs from some scrap wood and glue them in to fill the holes.
- o Before drilling the holes for the new inserts, it is important to create a relief recess in order to avoid popping the finish as the new inserts are threaded in. Do this by mounting template G1 on the guitar with the larger holes to the rear, aligning the scale and centerline marks. Using the holes in the template as location reference, use a 1/2" router bit to create an 1/8" deep recess at both locations.
- o Then flip the template around, and using the 25/64" drill bit drill holes about 3/4" deep. It is very important that these holes are very accurately located.
- o Using the insert driver tool, install the inserts straight into the hole. The alignment is critical.

### **G2 and G2X: Route the Pocket**

- o Mount template G2 using the two provided screws.
- o Mount the template G2X directly on top of G2 using double sided tape.
- o Using a Forstner bit on your drill press, clear out as much wood in the route area as you can to a depth of about 1 - 5/8".
- o With a 1/2" bearing-guided router bit, clean up the edges of the pocket.
- o You may have to use an unguided bit for the last pass or two in order to get down deep enough and dress the floor of the pocket to a nice flat surface at a depth of about 1 - 13/16".

### **Install Donor Plugs**

Glue in the donor plugs to fill the holes left by the old bridge threaded inserts, and trim off any excess that hangs into the pocket area. A thin saw is a good tool for this job.

### **Drill and Cut the Recessed Pocket**

- o Place the 3-hole drill guide block in the pocket and secure it with the bridge mounting bolts. Make sure there isn't a possibility of marring the finish as you tighten the screws.
- o Slide the long drill and drill bushing into a hole in the drill block and slowly drill the hole until the mark on the drill bit reaches the drill bushing. Drill all three holes.
- o Next install the 2-hole drill block and drill the remaining two holes in the same manner.
- o Using the dogleg chisel, chop out the remaining material until the recessed pocket is even with the floor and walls of the routed pocket.

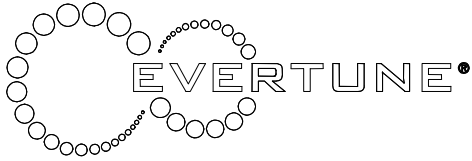

### Work on the Back, Template G3

To provide registration for the bottom templates, alignment holes need to be drilled from the top. Nestle the transfer punch in the rear corners of the routed pocket and put marks in each corner. Then using a drill press, drill 3/16" holes through the guitar at the marked locations. On the back of the guitar use the two resulting holes (7) to align the center punch and trace circles (8) around them. Also find the center between the two holes and mark a centerline on the back of the guitar. Mount the template G3 to the back of the guitar, aligning the rear corners (9) of the template to the circles (8), and the centerline of the template to the centerline of the guitar. Also transfer the scale length mark from the template to the back of the guitar for use in aligning the next template.

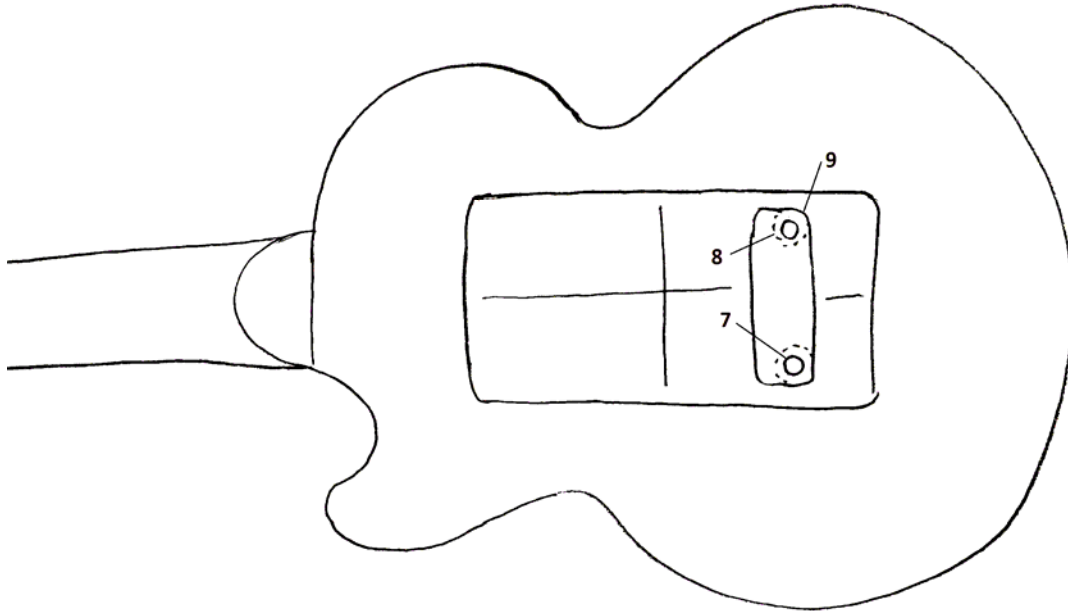

Route through the back and into the pocket created from the top. Now the guitar should look as shown below with the routed pocket and the centerline (10) and scale length (11) marks.

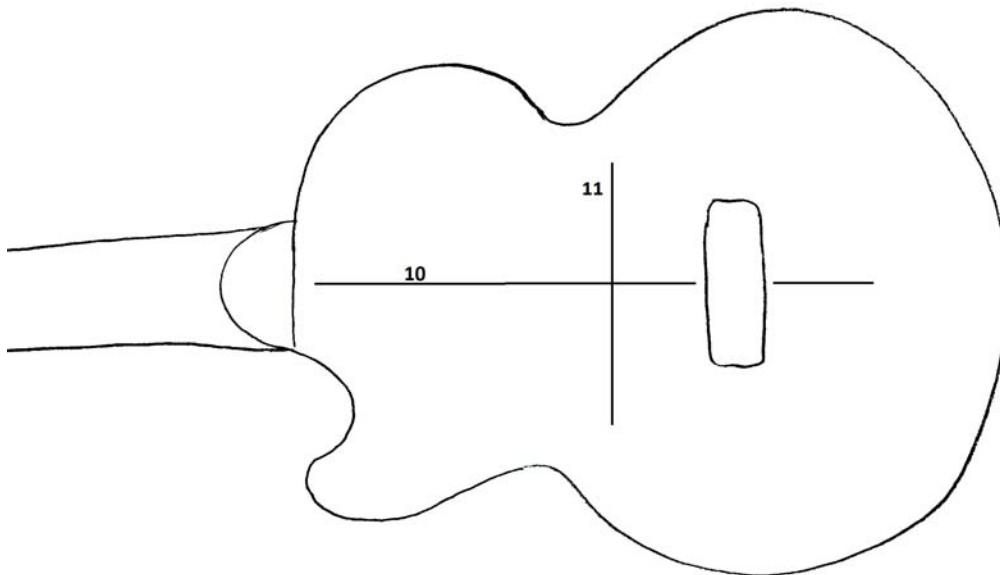

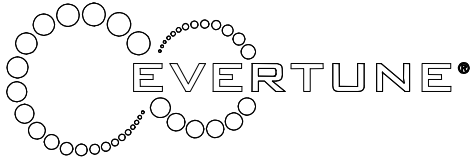

### Template G4

To act as a spacer for this shallow route, mount templates G2 and G2X sideways and stacked on top of each other as depicted on right. The edge of the opening in the template is aligned to the scale length mark on the guitar, and the scale length marks on the templates are aligned with the centerline of the guitar.

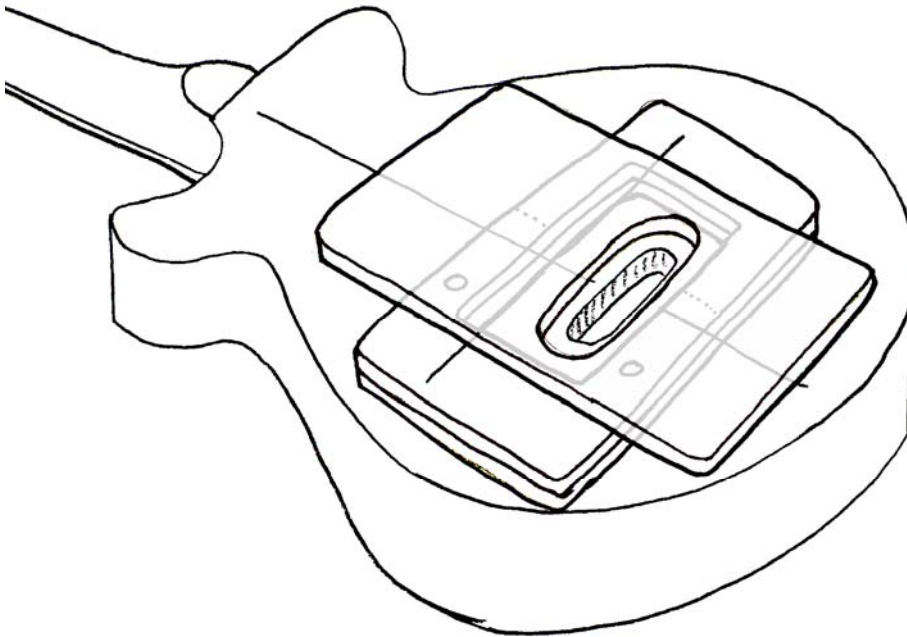
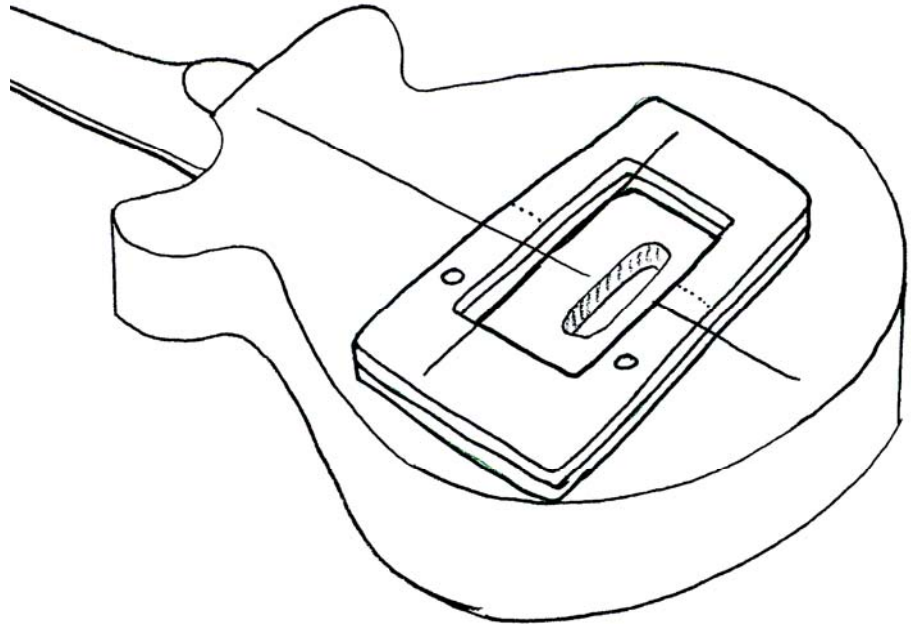

Then mount the template G4 as shown at left by sticking it to the spacer templates and aligning the scale length and centerline marks to the corresponding marks on the guitar, using the carefully aligned spacer templates as a guide. Route the pocket to a depth appropriate for the recessed rear cover plate.

### INSTALL THE BRIDGE

Provide a ground wire that will be trapped between the faceplate and the top of the guitar. With the bridge pickup loose, slip the pre-assembled bridge in from the top and secure the bridge with the two mounting bolts provided. Attach the back plate.

# G-DRILL DEPTH MARK

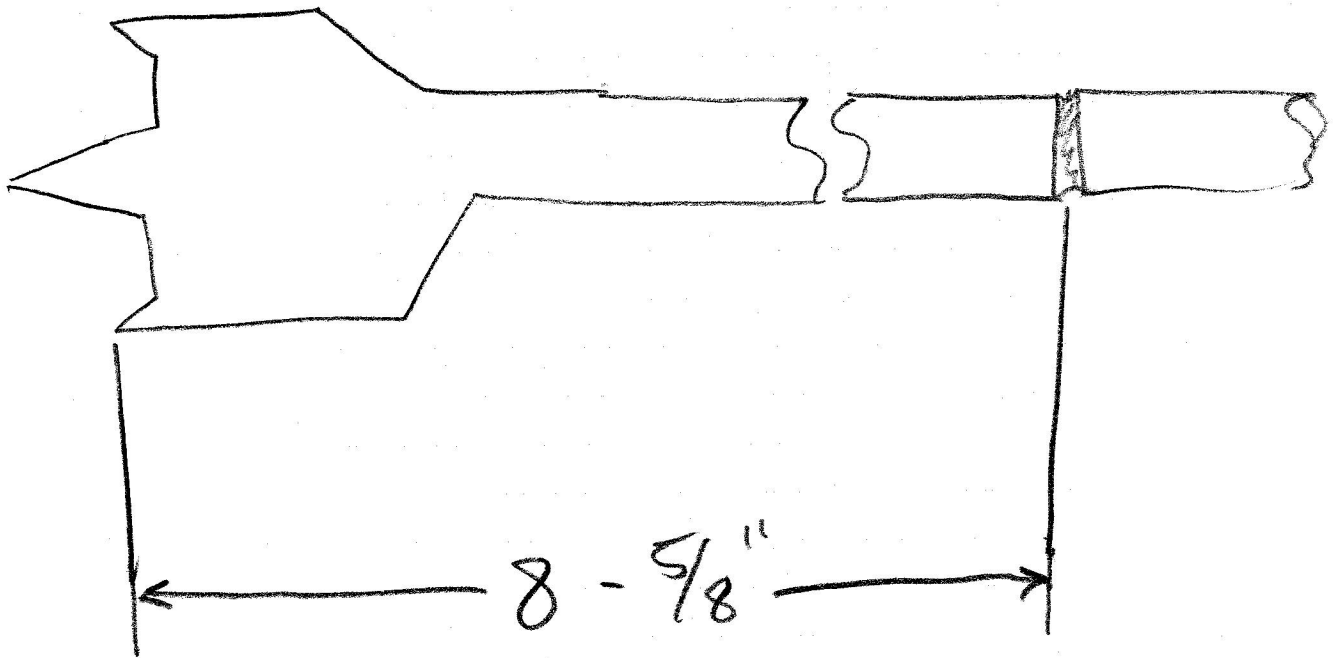

One part of the G Template set is a long spade bit. There is a need for a depth mark on the bit at the location shown above.